I M P O R T A N T

**CARE, USE & SERVICE
OF YOUR VOLLRATH
AFFORDABLE PORTABLE**

**3-WELL
HOT FOOD STATION**

No. 91935

No. 91936

No. 91938

I M P O R T A N T



THE VOLLRATH COMPANY • SHEBOYGAN, WI 53081



GENERAL OPERATING INSTRUCTIONS & MAINTENANCE

1. Plug unit into properly grounded receptacle only. Arcing will occur when connecting or disconnecting unit unless all controls are in the "Off" position.
2. Wells in Hot Food Units can be used dry, or with 2 quarts of hot water per well. If hot water is unavailable (180° or higher), cold water heated in the covered well will come to a boil in less than 1 hour. If the dry method is used, wells should be preheated for 15 minutes before inserting pans. During the preheating stage, all wells should be covered.
3. Control knobs on Hot Food Units in the range of Lo to 3 is low heat; 4 to 6, medium heat; and Hi is maximum. Because of variances in room temperature and conditions, food consistency and quantity, no specific instructions for settings can be given. Operation is similar to a home range — temperature of food should be checked periodically and the controls adjusted accordingly.
4. Each well will accommodate a 12" x 20" pan, 2½", 4" or 6" deep. Fractional size pans in various combinations can also be used with adaptor bars.
5. Any discoloration inside the wells can be removed with Ajax, Comet, steel wool or any commercial cleanser.
6. To keep stainless surface new looking, clean wells after each use to remove deposits. Then rinse thoroughly with clean water.
7. Clean the wood grain vinyl with a damp cloth or wax cleaner such as Pledge, etc.
8. All plastic breath protectors can be cleaned and polished with a clear plastic cleaner, Cadco's Brillianize, etc.
9. Wheel bearings should be greased as required.
10. Damaged cords and/or cord caps should be replaced.
11. Pilot lamps and controls are accessible by removing 4 screws (2 below and 2 behind control box) and sliding cover plate ahead.

STATION NO.	VOLTS	PHASE	AMPS	WATTS AC ONLY	PLUG NEMA	RECEPTACLE	
						HUBBELL	NEMA
91935	120	1	12.9	1545	5-15P	5261	5-15R
91936	240	1	6.5	1545	6-15P	5661	6-15R
91938	208	1	7.4	1545	6-15P	5661	6-15R

PARTS LIST

Your Vollrath mobile serving unit is designed to provide years of trouble-free use. If a part is damaged or lost, order a replacement part directly from: The Vollrath Company, 1236 N. 18th St., Sheboygan, WI 53081. A nominal charge will be made for the part(s) ordered, plus shipping and handling.

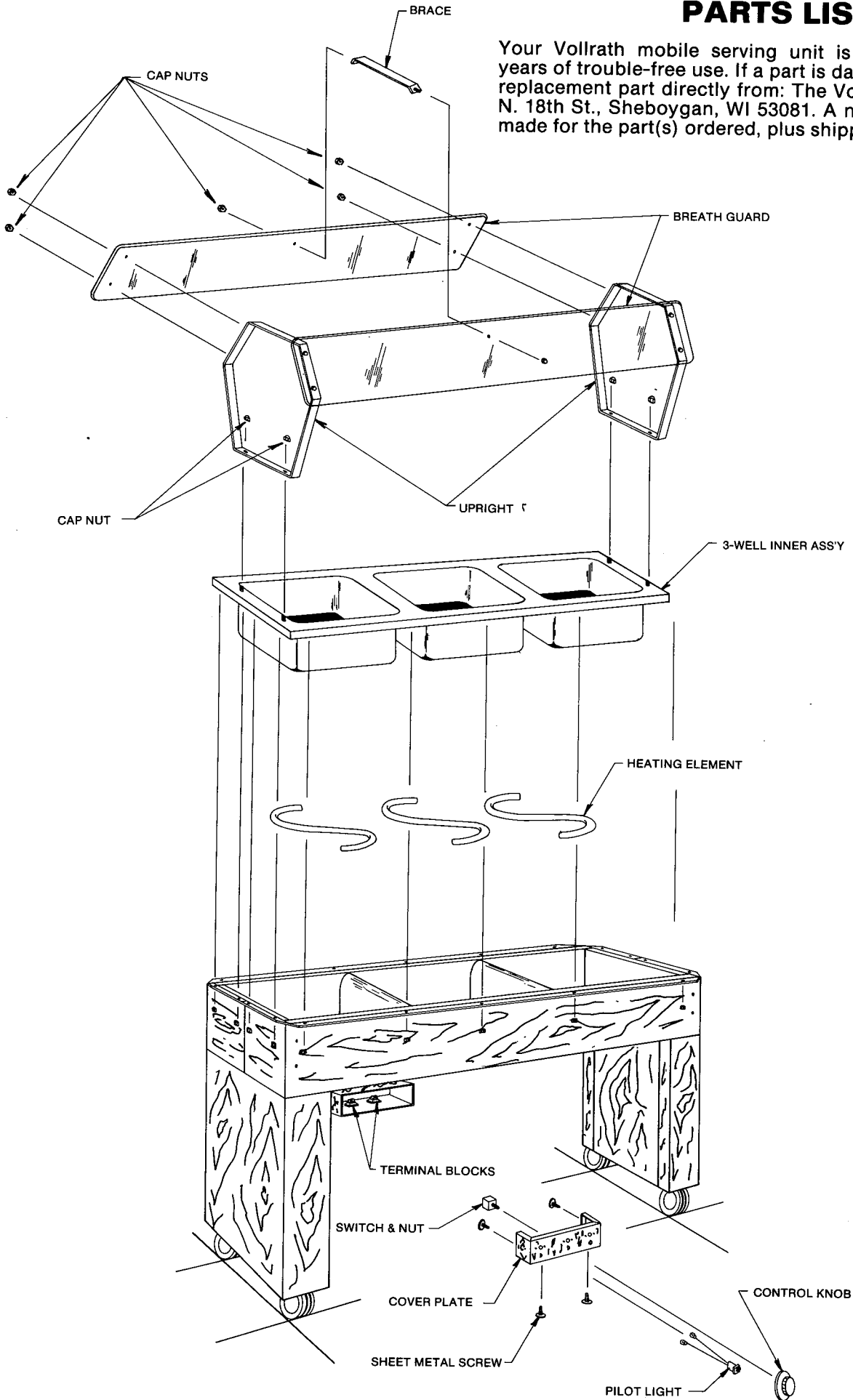

TROUBLE SHOOTING

1. In case of failure of any of the wells to heat up, disconnect power cord from outlet, remove four (4) screws from the control box panel, and pull out panel so it will hang by the wires.
2. Remove the two (2) wires connected to the H¹ and H² terminals from the control for the well in question, and take a resistance reading across the terminals H¹ and H² with the control knob turned to the "Off" position.

The reading should be 4000 Ohms for 120 Volt units and 15000 Ohms for 240 Volt and 208 Volt units. If not, the heater in the Robertshaw control is open and inoperative. Replace control.

3. If readings indicate heater is functioning, turn control knob to Hi and check for continuity between terminals L¹ and H¹, and between L² and H². The meter should read 0 Ohms for both readings. Replace control if any other reading is obtained.
4. If control has been found to be in working order, a resistance reading across the two (2) wires removed from H¹ and H² terminals should be taken.

The meter should indicate 25 Ohms (plus or minus 3 Ohms) for the 120 Volt units; and 105 Ohms (plus or minus 10 Ohms) for 240 Volt units; 70 Ohms (plus or minus 7 Ohms) for 208 Volt units.

An infinite reading indicates the element should be replaced.

REPLACING HEATING ELEMENTS

1. Remove all the 10-24 locknuts from the under-side of the top flange of the unit, and lift the well assembly out of the unit.
2. Remove nuts and washers from both ends of the heating element, slip the ringed connector off of the threaded studs of the element and twist top end of heating element retainers 90°, so element can be lifted out of the notches.
3. Position the replacement element into the retainer notches, direct the offset at the ends of element downward. Then turn top retainers back 90° and lower the well assembly into the unit. Be careful not to tear or misalign insulation along the sides of the unit.
4. Replace all the locknuts around the under-side of the top flange and pull up evenly, but not to extent to cause dimples to appear on the top surface of the well assembly.

**BREATH GUARD
ACCESSORY KIT
(Optional - Not included
with Standard Unit)**

Although your affordable portable buffet units are NSF listed, some local health codes require that the top and ends of the breath protector must be closed. In this case it would be necessary to attach an accessory breath guard kit. Kit may be ordered through your dealer, or contact The Vollrath Company, 1236 N. 18th St., Sheboygan, WI 53081. Order either:

KIT NO. 29460-1600
46" long, fits 3-well hot food station and utility station

KIT NO. 29610-1600
60" long, fits 4-well hot food station or cold food station

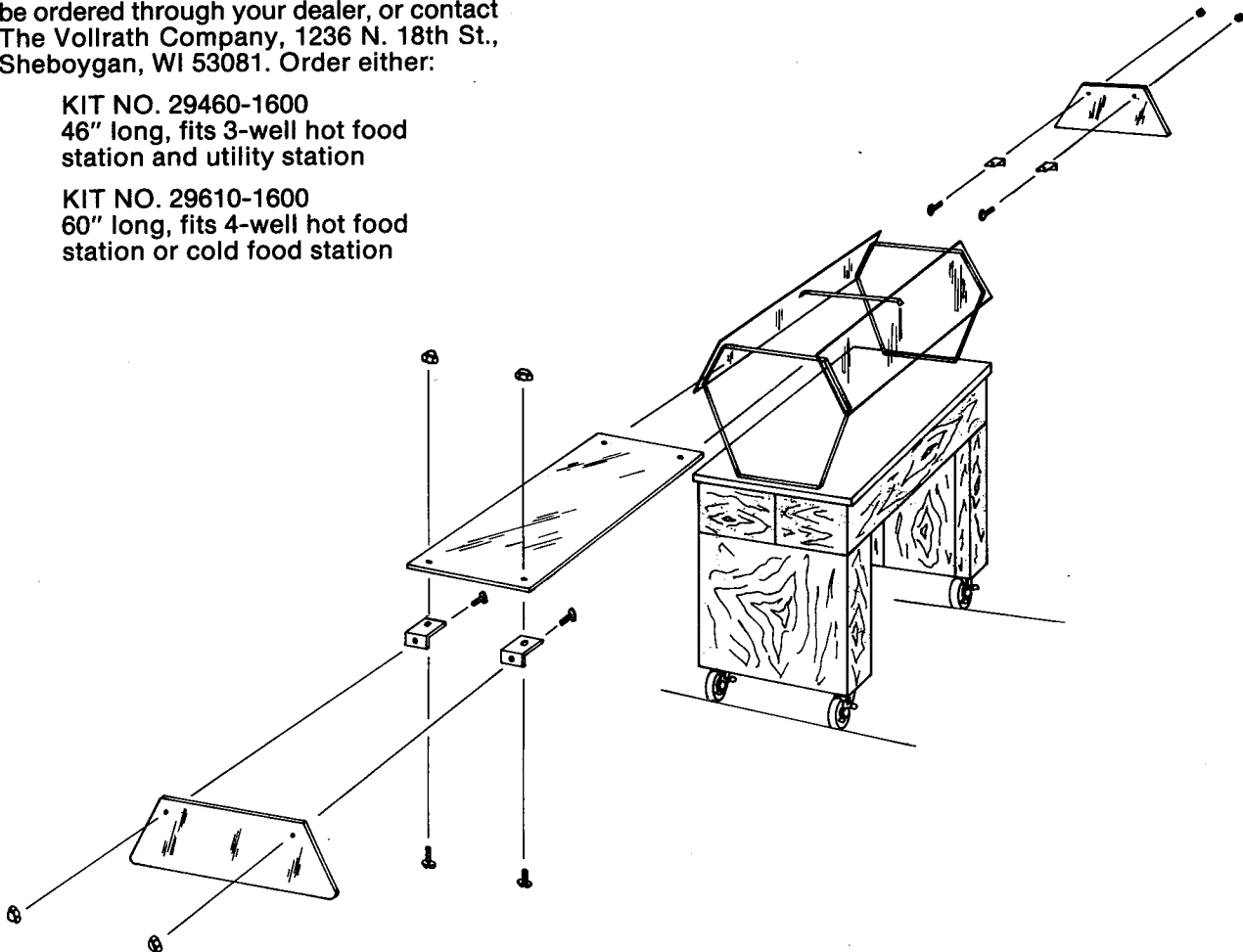

**TO ASSEMBLE ACCESSORY KIT
ON TO EXISTING
BREATH GUARD:**

1. Slide top protector over breath guard supports from either end.
2. Attach angle brackets to end protector with screws and cap nuts
3. Slip angle brackets between breath guard support and top protector. Fasten bracket to top protector with remaining screws and cap nuts.

EACH ACCESSORY KIT CONTAINS:

1 top protector, 2 end protectors, 4 angle brackets, 8 screws with cap nuts.

WIRING DIAGRAMS - HOT FOOD UNITS

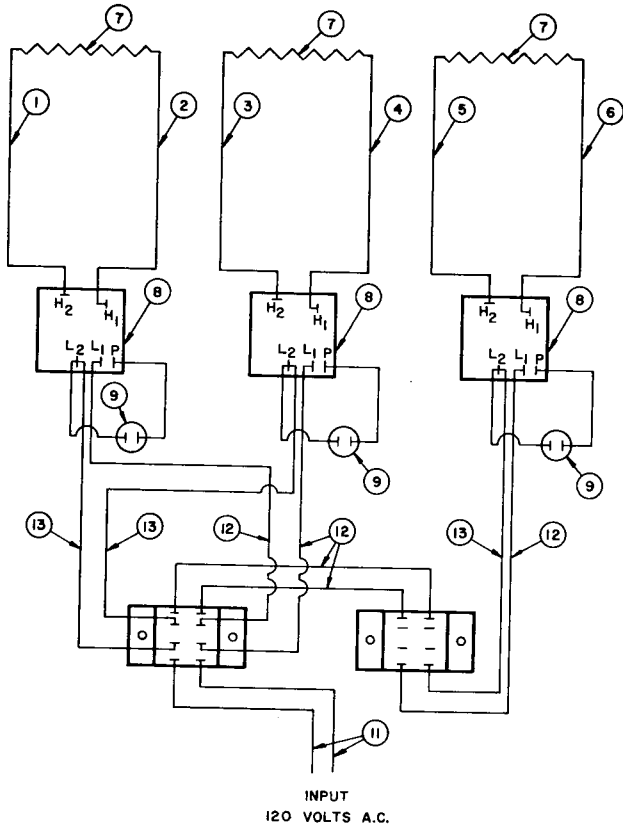

DET.	PART NO.	REQ'D	DESCRIPTION
1	25527-1058	1	23" BLACK WIRE TYPE (SF-2 OR SEW-2)
2	25529-1058	1	27" BLACK WIRE TYPE (SF-2 OR SEW-2)
3	25530-1058	1	27" BROWN WIRE TYPE (SF-2 OR SEW-2)
4	25547-1058	1	47" BROWN WIRE TYPE (SF-2 OR SEW-2)
5	25545-1058	1	47" BLUE WIRE TYPE (SF-2 OR SEW-2)
6	25552-1058	1	60" BLUE WIRE TYPE (SF-2 OR SEW-2)
7	24478-2560	3	HEATING ELEMENT
8	24788-1058	3	"ROBERTSHAW" SWITCH
9	23065-1058	3	PILOT LIGHT
10	24872-1058	2	TERMINAL BLOCK "MAQ-2"
11	25554-1058	2	60" RED WIRE TYPE (SF-2 OR SEW-2)
12	25523-1058	5	9" RED WIRE TYPE (SF-2 OR SEW-2)
13	25525-1058	3	9" RED-PIG BACK ONE END
14	21488-1058	1	CORD ASS'Y 14/3 TYPE S.O. (CAP 3 WIRE 15 A. 125 V.)
15	22860-1058	2	IDEAL WIRE NUT (NOT SHOWN)
16	22480-1058	3	CONTROL KNOBS (NOT SHOWN)
17			
18			
19			
20			

MODEL NO. 91935

DET.	PART NO.	REQ'D	DESCRIPTION
1	25527-1058	1	23" BLACK WIRE
2	25529-1058	1	27" BLACK WIRE
3	25530-1058	1	27" BROWN WIRE
4	25547-1058	1	47" BROWN WIRE
5	25545-1058	1	47" BLUE WIRE
6	25552-1058	1	60" BLUE WIRE
7	24477-2560	3	HEATING ELEMENT
8	24789-1058	3	"ROBERTSHAW" SW.
9	23066-1058	3	PILOT LIGHT
10	24872-1058	2	TERMINAL BLOCK
11	25554-1058	2	60" RED WIRE
12	25523-1058	5	9" RED WIRE
13	25525-1058	3	9" RED WIRE
14	21494-1058	1	CORD ASS'Y (3 WIRE)
15	22860-1058	2	WIRE NUT (NOT SHOWN)
16	22480-1058	3	CONTROL KNOB (NOT SHOWN)

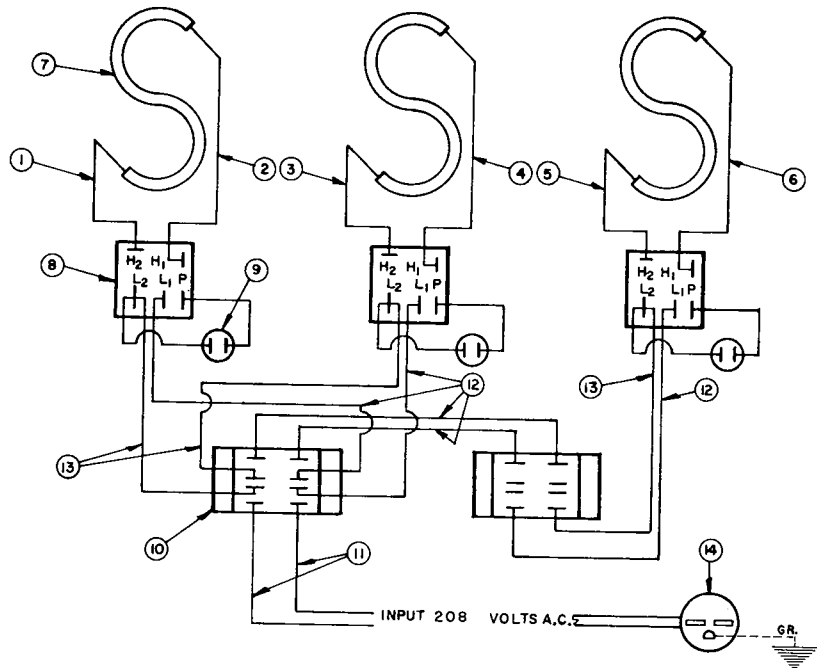

MODEL NO. 91938

DET.	PART NO.	REQ'D	DESCRIPTION
1	25527-1058	1	23" BLACK WIRE
2	25529-1058	1	27" BLACK WIRE
3	25530-1058	1	27" BROWN WIRE
4	25547-1058	1	47" BROWN WIRE
5	25545-1058	1	47" BLUE WIRE
6	25552-1058	1	60" BLUE WIRE
7	24479-2560	3	HEATING ELEMENT
8	24789-1058	3	"ROBERTSHAW" SW.
9	23066-1058	3	PILOT LIGHT
10	24872-1058	2	TERMINAL BLOCK
11	25554-1058	2	60" RED WIRE
12	25523-1058	5	9" RED WIRE
13	25525-1058	3	9" RED WIRE
14	21494-1058	1	CORD ASS'Y (3 WIRE)
15	22860-1058	2	WIRE NUT (NOT SHOWN)
16	22480-1058	3	CONTROL KNOB (NOT SHOWN)

MODEL NO. 91936

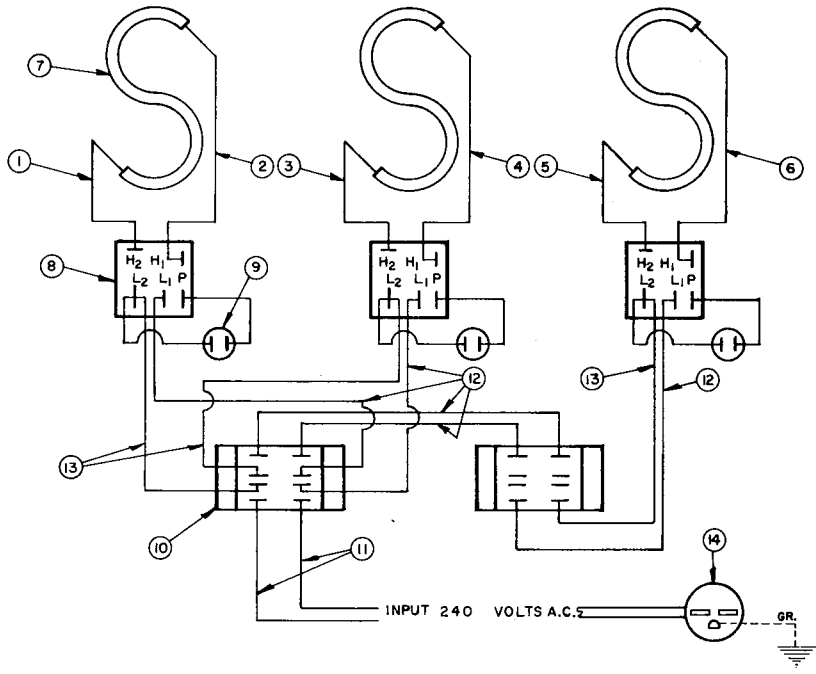

**WARRANTY REGISTRATION—AFFORDABLE PORTABLE
VOLLRATH HOT FOOD STATION**

OWNER'S NAME _____

OWNER'S STREET ADDRESS _____

CITY _____ STATE _____ ZIP CODE _____

MODEL NO. _____ SERIAL NO. _____

PURCHASED FROM _____ DATE PURCHASED _____

CITY _____ STATE _____ ZIP CODE _____

COMMENTS: _____

NOTE: RETAIN THIS COPY FOR YOUR FILE _____

YOUR COPY

**IMPORTANT! WARRANTY REGISTRATION — AFFORDABLE
PORTABLE HOT FOOD STATION**

MODEL NO.: _____ DATE OF PURCHASE: _____

SERIAL NO.: _____

OWNER'S NAME: _____

ADDRESS: _____

PRODUCT PURCHASED FROM: _____

REASONS FOR SELECTION OF OUR PRODUCT: APPEARANCE QUALITY DURABILITY
 AVAILABILITY PRICE VERSATILE USE EASE OF OPERATION

DO YOU HAVE OTHER PRODUCTS OF THE SAME BRAND? _____

IF OTHER BRAND, WHICH BRAND? _____

ARE THEY: BUFFETS CAFETERIAS FREEZER COOLERS TRANSPORT CARRIERS

YEAR OF PURCHASE OF THE OTHER UNITS:

01	<input type="checkbox"/>	FULL MENU REST.-CHAIN	06	<input type="checkbox"/>	SCHOOL	11	<input type="checkbox"/>	OTHER INSTITUTIONS
02	<input type="checkbox"/>	LIMITED MENU REST.-INDEPENDENT	07	<input type="checkbox"/>	COLLEGE	12	<input type="checkbox"/>	RETIREMENT HOME OR VILLAGE
03	<input type="checkbox"/>	LIMITED MENU REST.-CHAIN	08	<input type="checkbox"/>	HOSPITAL	13	<input type="checkbox"/>	CONTRACT FEEDER
04	<input type="checkbox"/>	LIMITED MENU REST.-INDEPENDENT	09	<input type="checkbox"/>	NURSING HOME	14	<input type="checkbox"/>	EMPLOYEE FEEDING
05	<input type="checkbox"/>	HOTEL-MOTEL	10	<input type="checkbox"/>	PENAL INSTITUTIONS	15	<input type="checkbox"/>	CATERING

TYPE OF SERVICE: 01 TABLECLOTH 02 COUNTERTOP 03 CAFETERIA 04 CARRY OUT

NUMBER OF EMPLOYEES: 01 10 AND UNDER 02 11 TO 25 03 26 TO 50 04 51 TO 100 05 100 AND OVER

NOTE: Warranty is void unless this card is returned within 15 days after date of purchase.
Please Fill Out and Mail Warranty Card Immediately!

**BREATH GUARD
ACCESSORY KIT
(Optional - Not included
with Standard Unit)**

Although your affordable portable buffet units are NSF listed, some local health codes require that the top and ends of the breath protector must be closed. In this case it would be necessary to attach an accessory breath guard kit. Kit may be ordered through your dealer, or contact The Vollrath Company, 1236 N. 18th St., Sheboygan, WI 53081. Order either:

KIT NO. 29460-1600
46" long, fits 3-well hot food
station and utility station

KIT NO. 29610-1600
60" long, fits 4-well hot food
station or cold food station

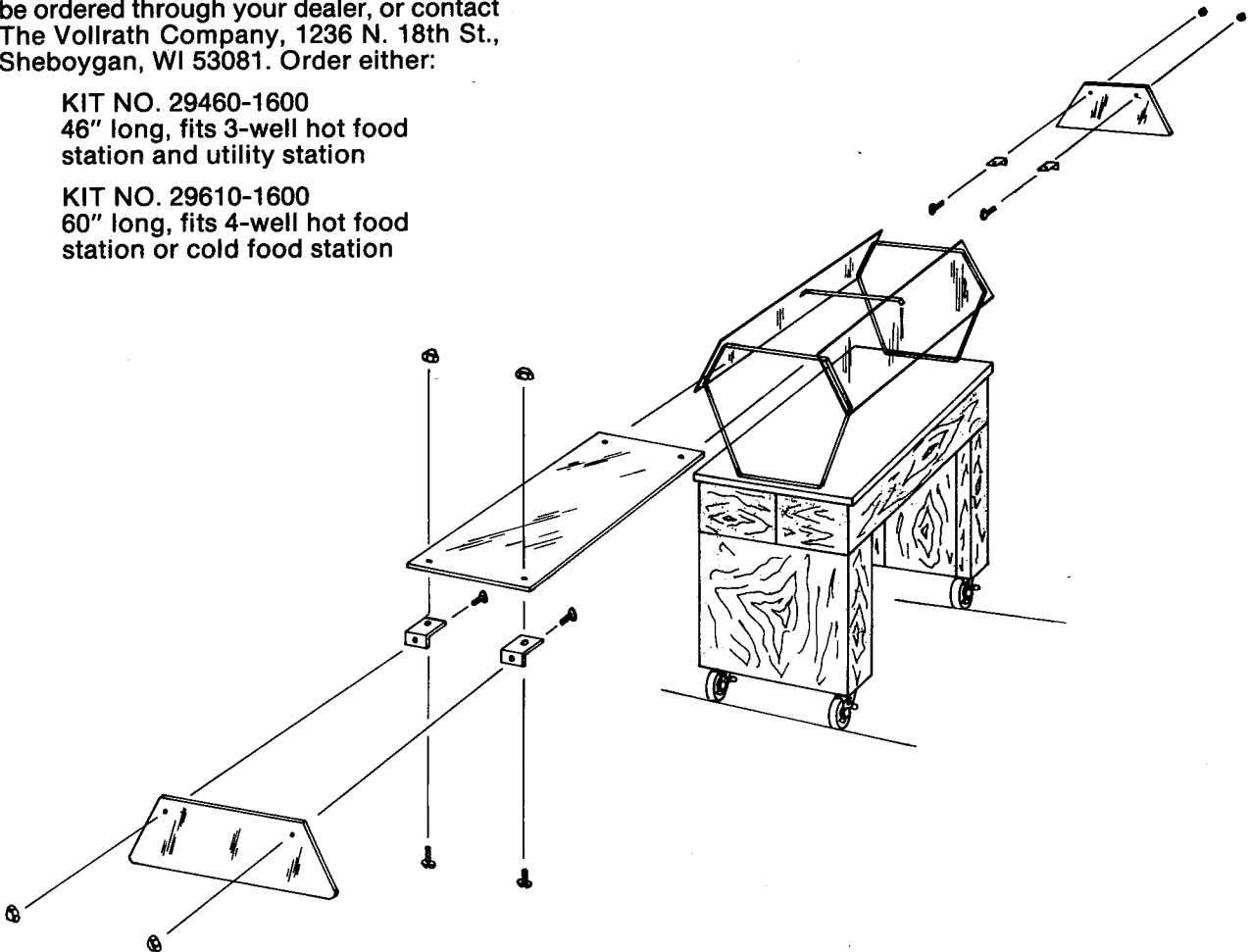

**TO ASSEMBLE ACCESSORY KIT
ON TO EXISTING
BREATH GUARD:**

1. Slide top protector over breath guard supports from either end.
2. Attach angle brackets to end protector with screws and cap nuts
3. Slip angle brackets between breath guard support and top protector. Fasten bracket to top protector with remaining screws and cap nuts.

EACH ACCESSORY KIT CONTAINS:

1 top protector, 2 end protectors, 4 angle brackets, 8 screws with cap nuts.